

# Installation and Operation Guide

## RTI Commercial Amplifiers

**AMP-4-125**      4 Channel 125W 8 $\Omega$ ,  
2 Channel 70/100V 250W DSP Matrix Amplifier

**AMP-8-125**      8 Channel 125W 8 $\Omega$ ,  
4 Channel 70/100V 250W DSP Matrix Amplifier



It's Under Control<sup>®</sup>

## Important Safety Instructions

1. Read these instructions.
2. Keep these instructions.
3. Heed all warnings.
4. Follow all instructions.
5. Do not use this apparatus near water.
6. Do not submerge the equipment in water or liquids.
7. Do not use any aerosol spray, cleaner, disinfectant or fumigant on, near or into the equipment.
8. Clean only with a dry cloth.
9. Do not block any ventilation opening. Install in accordance with the manufacturer's instructions.
10. Do not install near any heat sources such as radiators, heat registers, stoves, or other apparatus (including amplifiers) that produce heat.
11. To reduce the risk of electrical shock, the power cord shall be connected to a mains socket outlet with a protective earthing connection.
12. Do not defeat the safety purpose of the polarized or grounding type plug. A polarized plug has two blades with one wider than the other. A grounding type plug has two blades and a third grounding prong. The wide blade or the third prong are provided for your safety. If the provided plug does not fit into your outlet, consult an electrician for replacement of the obsolete outlet.
13. Protect the power cord from being walked on or pinched particularly at plugs, convenience receptacles, and the point where they exit from the apparatus.
14. Do not unplug the unit by pulling on the cord, use the plug.
15. Only use attachments/accessories specified by the manufacturer.
16. Unplug this apparatus during lightning storms or when unused for long periods of time.
17. Refer all servicing to qualified service personnel. Servicing is required when the apparatus has been damaged in any way, such as power supply cord or plug is damaged, liquid has been spilled or objects have fallen into the apparatus, the apparatus has been exposed to rain or moisture, does not operate normally, or has been dropped.

18. The appliance coupler, or the AC Mains plug, is the AC mains disconnect device and shall remain readily accessible after installation.
19. Adhere to all applicable, local codes.
20. Consult a licensed, professional engineer when any doubt or questions arise regarding a physical equipment installation.



## Environmental Statement

This product complies with international directives, including but not limited to the Restriction of Hazardous Substances (RoHS) in electrical and electronic equipment, the Registration, Evaluation, Authorization and restriction of Chemicals (REACH) and the disposal of Waste Electrical and Electronic Equipment (WEEE). Consult your local waste disposal authority for guidance on how properly to recycle or dispose of this product.

# Table of Contents

<b>Topic</b>	<b>Page</b>
Introduction and Overview .....	<a href="#">3</a>
Installation .....	<a href="#">7</a>
Power, Network, and Wi-Fi .....	<a href="#">10</a>
Configuration Menus: Dashboard and Input .....	<a href="#">11</a>
Configuration Menus: EQ and Zones .....	<a href="#">12</a>
Configuration Menus: Output .....	<a href="#">14</a>
Configuration Menus: Speaker Presets .....	<a href="#">15</a>
Configuration Menus: Settings .....	<a href="#">16</a>
Signal Flow Schematic .....	<a href="#">18</a>
Input Setup, Routing, GPIO Connection .....	<a href="#">19</a>
Connections .....	<a href="#">21</a>
Operation .....	<a href="#">25</a>
Specifications .....	<a href="#">26</a>

## Introduction and Overview

### 1. Introduction

The AMP-4-125 and AMP-8-125 power amplifiers have been designed to provide configurable, consistent and reliable high performance audio power amplification for residential, commercial and entertainment applications. Please read this manual fully before installing and using the amplifier. If you have any questions regarding amplifier configuration, installation or operation please contact the appropriate customer support portal.

Following this introduction, the manual is divided into sections covering the following topics:

- 2. Overview
- 3. Carton Contents
- 4. Installation
- 5. Configuration
- 6. Connections
- 7. Operation
- 8. Specifications

### 2. Amplifier Overview

The AMP-4-125 and AMP-8-125 are half rack and full rack width respectively, 1U format power amplifiers that can drive both conventional low impedance (Lo-Z, 4Ω to 16Ω) loudspeakers and high impedance (Hi-Z, 70V/100V) transformer coupled loudspeakers.

The amplifiers provide four or eight analog inputs depending on model type, one stereo S/PDIF digital input, and either four or eight outputs (Lo-Z mode), or two or four outputs (Hi-Z mode).

The AMP-4-125 and AMP-8-125 amplifiers also incorporate automatic power sharing technology that enables power to be shared proportionately as required between pairs of outputs in Lo-Z mode.

The AMP-4-125 and AMP-8-125 amplifier model rack widths, output channel counts and power outputs are as follows:

#### AMP-4-125 (half rack width)

Mode	Channels	Max Rated Output per Channel
Lo-Z	Four	125 Watts
Hi-Z	Two	250 Watts

#### AMP-8-125 (full rack width)

Mode	Channels	Max Rated Output per Channel
Lo-Z	Eight	125 Watts
Hi-Z	Four	250 Watts

# Introduction and Overview

## 2.1 Connections

AMP-4-125 and AMP-8-125 signal input and output connections are accomplished via RCA Phono and Euroblock style connectors. A GPIO (General Purpose In/Out) Euroblock connector enables some amplifier functions to be controlled, and wireless or RJ45 socket Ethernet network connection options are also provided.

The AMP-4-125 and AMP-8-125 have no mains power switch and are operational as soon as mains power is connected via the IEC 60320 mains socket.

## 2.2 Network Features

The AMP-4-125 and AMP-8-125 amplifiers are TCP/IP network connected devices that require a wired or wireless network connection to access their configuration menus. The configuration menus are accessed via the control web app interface and cover Input, Zone, Output and General Settings functions. The configuration menus are fully described in Section 6 of this manual.

## 2.3 Dimensions

AMP-4-125 and AMP-8-125 dimensions and features are illustrated in Diagrams 2A and 2B. The amplifiers are primarily intended for installation in an equipment rack but in some cases can also be under-desk or wall mounted, or used free standing. They are fan-cooled and must be installed such that ventilation apertures are not obstructed.

## 2.4 Firmware

This manual describes the features, functions and user interface of the AMP-4-125 and AMP-8-125 running Firmware Version 1.7.2.



We strongly recommend that the firmware version installed in the amplifier in use is checked initially, and regularly thereafter. If updated firmware is available, the amplifier should be updated as a priority.

The firmware installed in the amplifier can be identified and updated by selecting the Device option in the Control web app Settings Menu. Firmware versions can be checked, and firmware downloaded, from the AMP-4-125 and AMP-8-125 website: <http://www.rticontrol.com>. Firmware can be found at <https://www.rticontrol.com/dealer/firmware> (Dealer login is required).

## 3. Carton Contents

The AMP-4-125 and AMP-8-125 amplifiers are shipped in a cardboard carton containing the amplifier unit, a mains cable appropriate for the sales territory, an accessory pack, and a document pack. The full contents is listed below.

- Amplifier unit
- Mains power cable
- Input connector x 2 or 4
- GPIO socket connector x 1
- Output connector x 1, 2 or 4
- Adhesive rubber feet x 4
- Set of rack ears
- Document pack

**Diagram 2A**

AMP-4-125 dimensions.

(Shaded area defines ventilation space.)

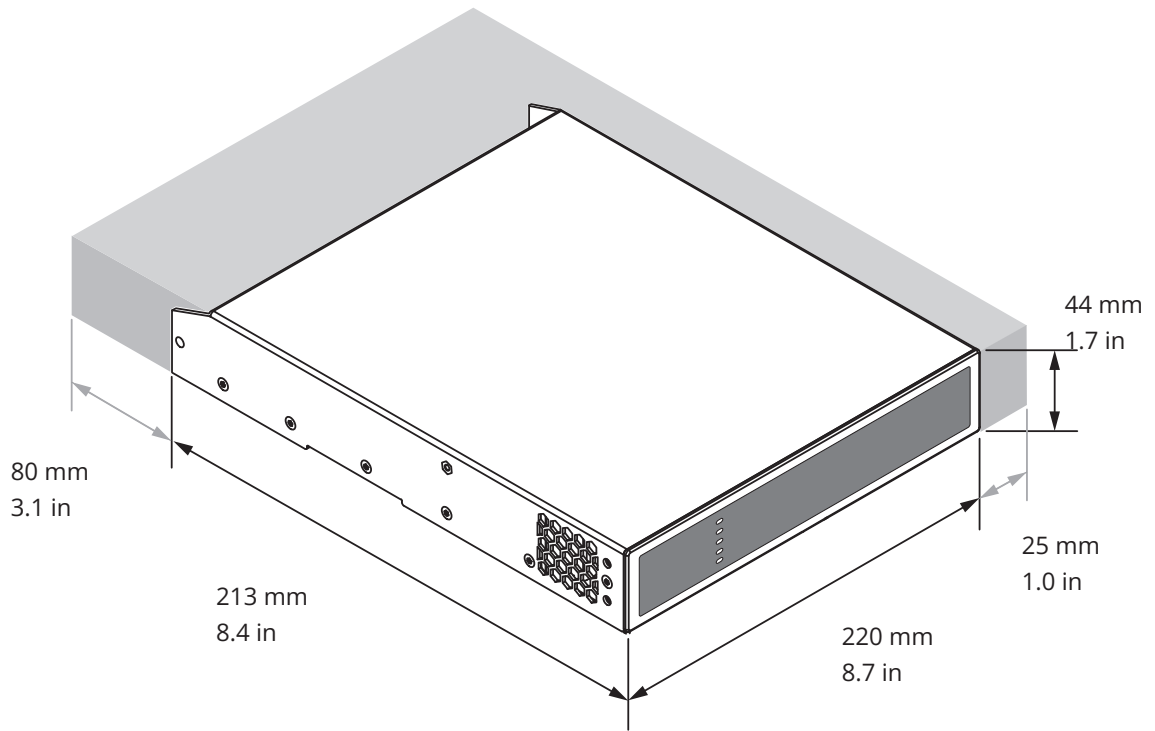
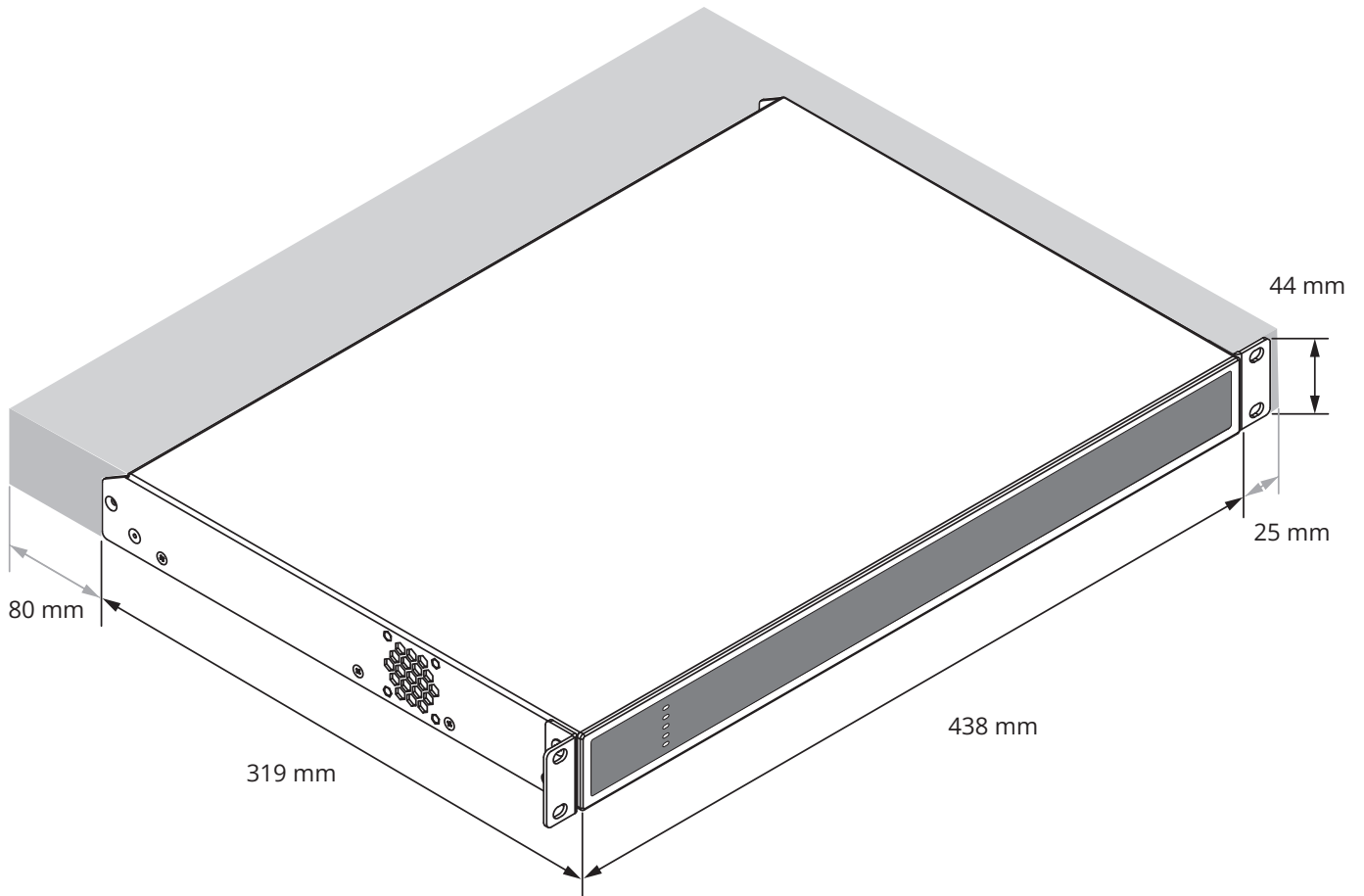

Diagram 2B  
AMP-8-125 dimensions.  
(Shaded area defines ventilation space.)



# Installation

## 4. AMP-4-125 Half Rack Width Amplifier Installation

Diagram 4A

AMP-4-125

Rack Ear + Half-rack Extension.

### 4.1 AMP-4-125 Mounting

AMP-4-125 half rack width amplifiers are shipped without rack mount hardware attached but can be configured for rack installation using one standard rack 'ear' and one half-rack extension piece as illustrated in Diagram 4A. The installation and equipment rack should be configured to provide appropriate ventilation airflow space around the sides and rear of the amplifier. Ventilation airflow space of at least 25 mm (1 in) should be maintained along at least one side of the amplifier at all times. Ventilation apertures are also located on the rear panel of the amplifier and must not be obstructed. It is important to retain at least 80 mm (3.1 in) free space for airflow behind the amplifier rear panel.

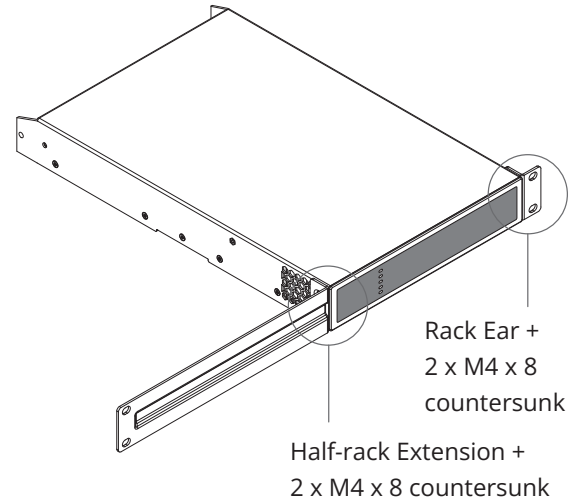

Multiple AMP-4-125 half rack width amplifiers can also be mechanically connected using an accessory connecting plate. Diagram 4B illustrates the use of a connecting plate. A connection plate is included in the kit shown in Diagram 4B. Together with 2 x rack ears a connection plate enables a pair of amplifiers to be joined and installed in a full width rack space.

Diagram 4B

2 x AMP-4-125 with Connection Plate.

2 positions

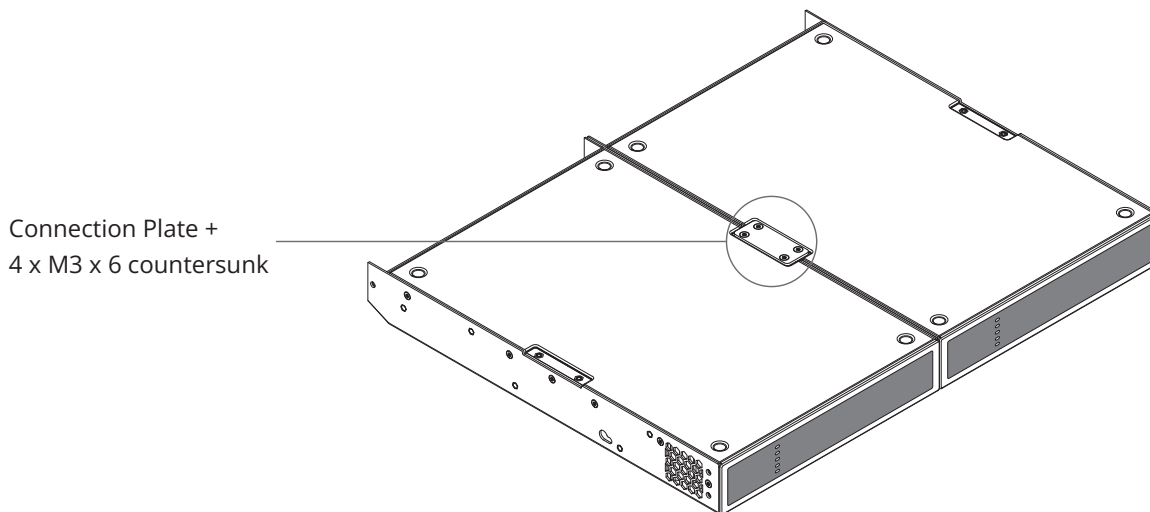

# Installation

## 4.2 Free-standing

If not installed in an equipment rack, the AMP-4-125 amplifier can be placed free-standing on a flat surface. Adhesive rubber feet are supplied for this purpose.

The AMP-4-125 amplifier can also be attached to the underside of desks or wall mounted using connecting plate hardware. The adhesive rubber feet should also be used in these circumstances to minimise the possibility of vibration between the amplifier and mounting surface. Wall and desk mounting is illustrated in Diagrams 4C and 4D.

It is important in any free standing installation that airflow through the amplifier's side panel mounted fans and rear panel ventilation apertures is not compromised by adjacent items. At least 80mm of free space behind the amplifier and 25mm along at least one side should be retained at all times.

**Diagram 4C**

AMP-4-125

with desk/wall Mounting Plate and adhesive feet.  
2 positions and 4 positions.

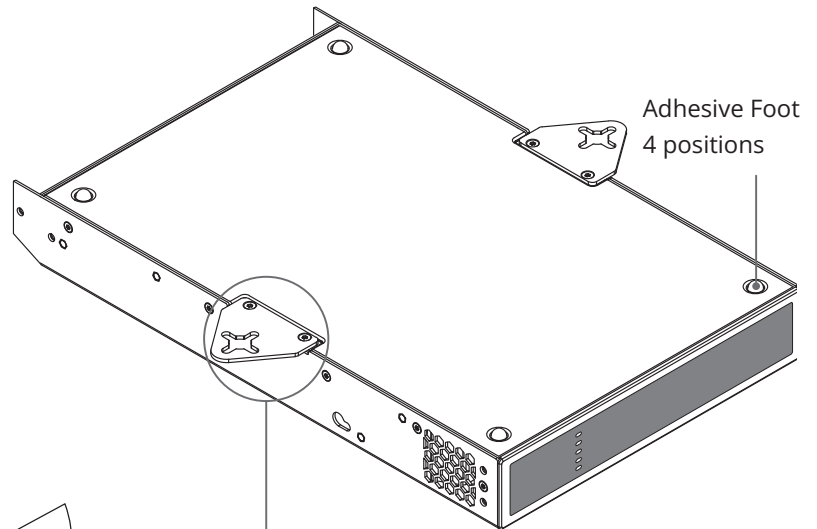

Adhesive Foot  
4 positions

Mounting Plate +  
2 x M3 x 6 countersunk

**Diagram 4D**

AMP-4-125

wall and under-desk mount.

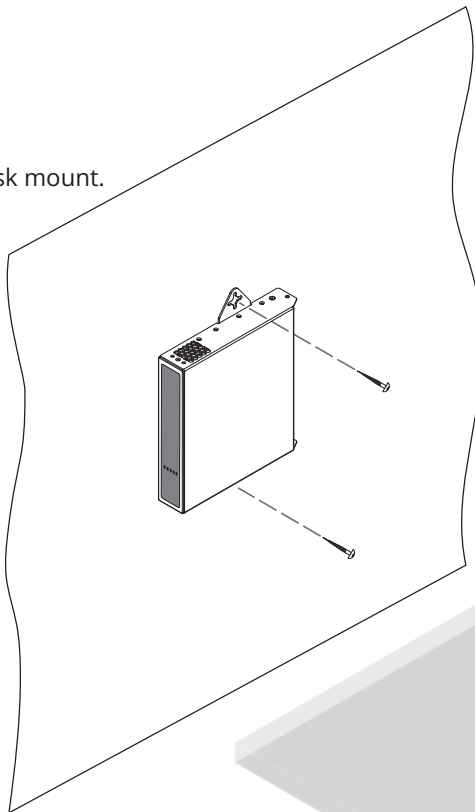

*Note: Full rack width amplifiers are not suitable for under-desk or wall mount installation.*

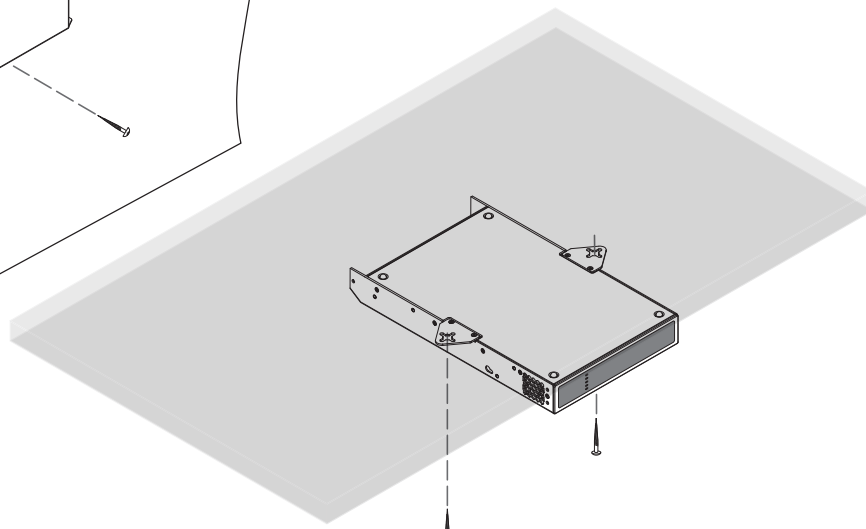



# Installation

## 5. AMP-8-125 Full Rack Width Amplifier Installation

Note: Full rack width AMP-8-125 is intended for rack mount or free-standing installation only.

### 5.1 Rack Mounting

The AMP-8-125 full rack width amplifier is supplied with rack ears fitted. The installation and equipment rack should be configured to provide appropriate ventilation airflow space around the sides and rear of the amplifier. Ventilation airflow space of at least 25 mm (1 in) should be maintained along at least one side of the amplifier at all times. Ventilation apertures are also located on the rear panel of the amplifier and must not be obstructed. It is important to retain at least 80 mm (3.1 in) free space for airflow behind the amplifier rear panel.

### 5.2 Free-standing

If not installed in an equipment rack, the AMP-8-125 full rack width amplifier can be placed free-standing on a flat surface. Adhesive rubber feet are supplied for this purpose. Diagram 5A illustrates the adhesive foot locations.

**Diagram 5A**  
AMP-8-125  
Adhesive feet

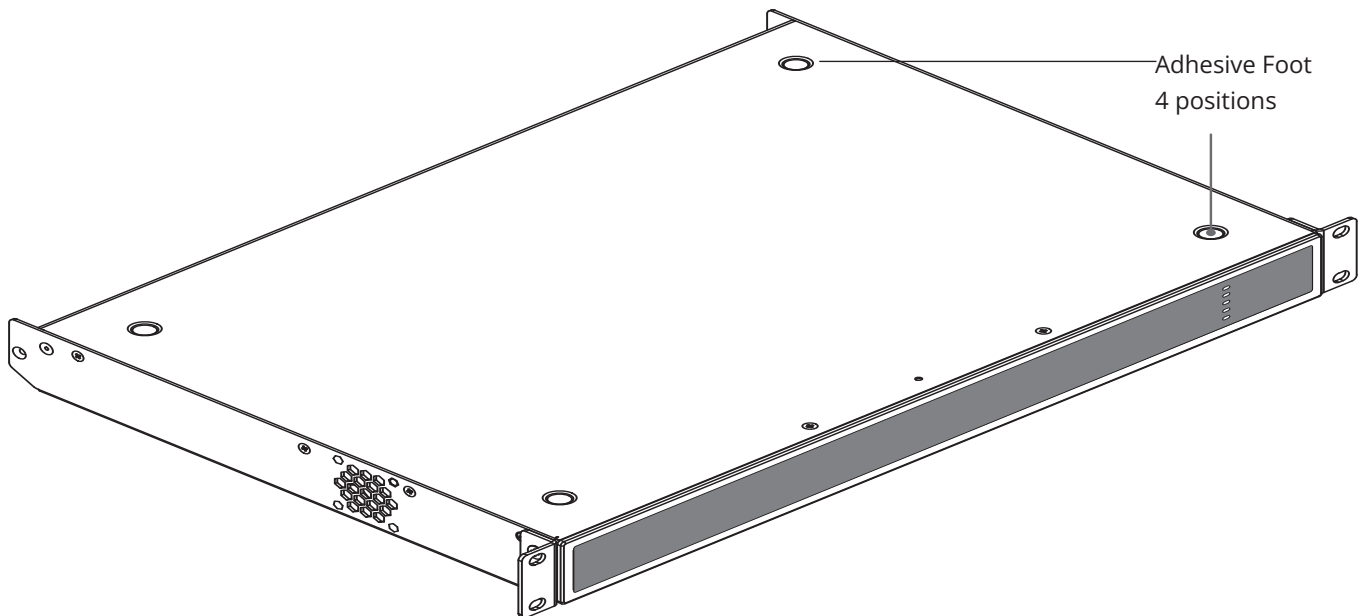

# Configuration

## 6. Configuration

Before making input, output and GPIO connections, an initial AMP-4-125 or AMP-8-125 amplifier configuration should be established. It is particularly important that the amplifier output format is configured appropriately for the speakers that are to be connected.

Configuration requires that AMP-4-125 and AMP-8-125 amplifiers are connected to mains power and network services. These connections are described in the following two sections.

### 6.1 Mains Power Connection

AMP-4-125 and AMP-8-125 amplifiers incorporate a power factor corrected power supply and can be used with mains input voltage from 100V AC to 240V AC, 50/60Hz. Use the mains cable supplied with the amplifier and connect it to a switched mains supply.

AMP-4-125 and AMP-8-125 amplifiers have no mains power switch and are operational as soon as mains power is connected.

### 6.2 Network Services

AMP-4-125 and AMP-8-125 amplifiers are configured via a web page. Before the configuration menus can be accessed, the amplifier(s) must be connected to the same TCP/IP network as the computer or mobile device that is to be used for configuration access.

#### 6.2.1 Wired (Ethernet) Network Connection

To connect the amplifier to a TCP/IP network using a wired connection (Ethernet) follow the steps below.

1. Use an Ethernet cable to connect the amplifier rear panel Network Control socket (upper socket) to a free socket on a network router or switch.
2. Connect the amplifier to mains power using the supplied mains cable. Wait for the front panel Network indicator to illuminate green to indicate that the amplifier has network connectivity.
3. The AMP-4-125 and AMP-8-125 amplifiers are set to DHCP by default. The network router will automatically assign the amplifier an IP address. A network scanning application can be used if required to identify the amplifier's IP address.
4. Open a web browser page and enter the amplifier's IP address. The amplifier's Control Web App interface will open to enable amplifier configuration as required.

*Note: If the amplifier is power cycled while using DHCP, it is*

*possible that the network router will assign it a different IP address, leaving its configuration page inaccessible via the previous address. If this occurs, a network scanning app can be used to identify the new IP address. DHCP and Fixed IP address option settings can be found in the Settings Tab menu described in Section 6.3. It's recommended to use a MAC reservation in the network router.*

### 6.2.2 Wireless (WiFi) Network Connection

To connect a AMP-4-125 or AMP-8-125 amplifier to a TCP/IP network using a wireless connection (WiFi) follow the steps below.

1. With the amplifier connected to mains power, wait for the front panel WiFi indicator to illuminate green.
2. Use a mobile, laptop or desktop device to search for available WiFi networks. Connect to the AMP-4-125 or AMP-8-125 (product serial number) using the password, '**password**'. The amplifier serial number can be found on its rear panel.
3. Open a computer or mobile device web browser and enter the IP address: 192.168.4.1. The Control Web App interface will open to enable amplifier configuration as required.
4. Select the Web App Settings Tab followed by WiFi > WiFi Mode > Client to configure the amplifier to connect to the required WiFi network. The WiFi network name and password will be required.

**It is strongly recommended that the amplifier Access Point WiFi password is changed following initial wireless connection.**

## 6.3 Configuration Menus

Opening a web browser that is network connected to the amplifier initially displays the Control Web App Dashboard illustrated in Diagram 6A. The Dashboard is the 'home' page from which all other configuration options can be accessed.

The Dashboard displays the amplifier status, output zones and the configuration menu tabs. It also enables immediate access to zone volume control. The functions available under each configuration menu tab are described in the following sections.

# Configuration

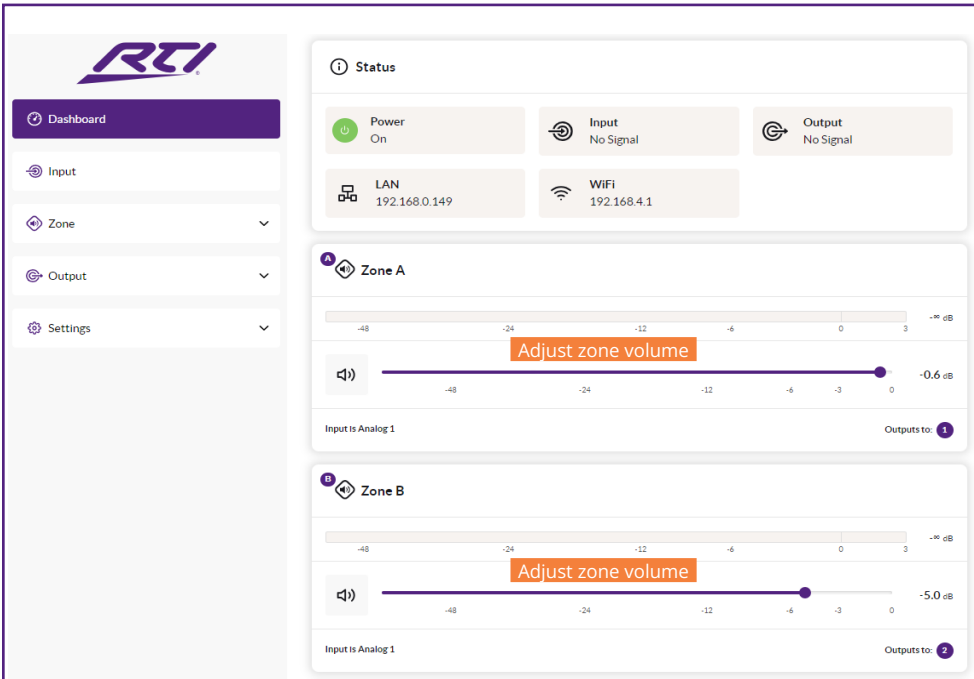

Diagram 6A  
Configuration Dashboard display

### 6.3.1 Input Tab

The Input Tab (Diagram 6B) provides the following configuration parameters for each amplifier input channel:

- Input name
- Mono/Stereo selection
- Input sensitivity
- High-pass filter
- Gain trim
- Five band equalization

The Input Tab also enables input signals to be mixed and routed to specific amplifier zones. The mix function enables any amplifier input, including stereo or split mono S/PDIF inputs, to be grouped with any other input or inputs to create multiple predefined mixes.

*Note: When adjusting the input gain, the input level display should remain green. If it displays red, reduce the input gain.*

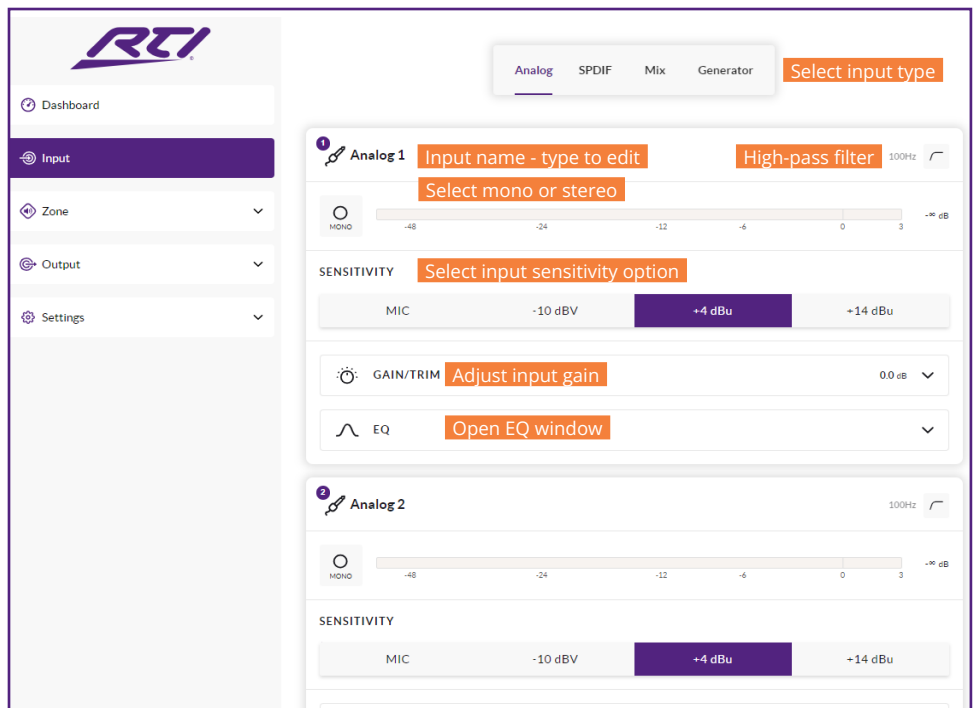

Diagram 6B  
Input Tab display  
(only two inputs shown)

# Configuration

Diagram 6C  
Input EQ display

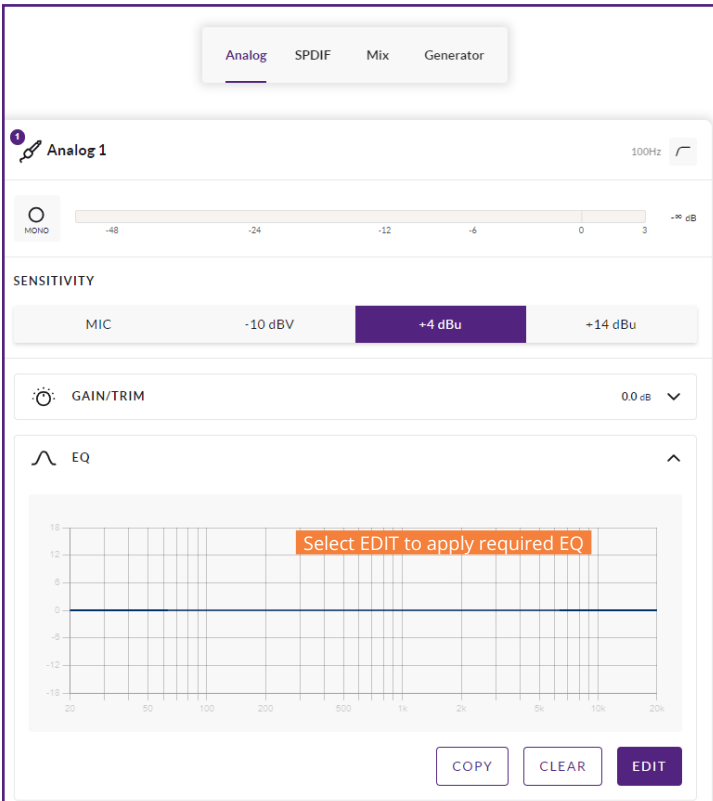
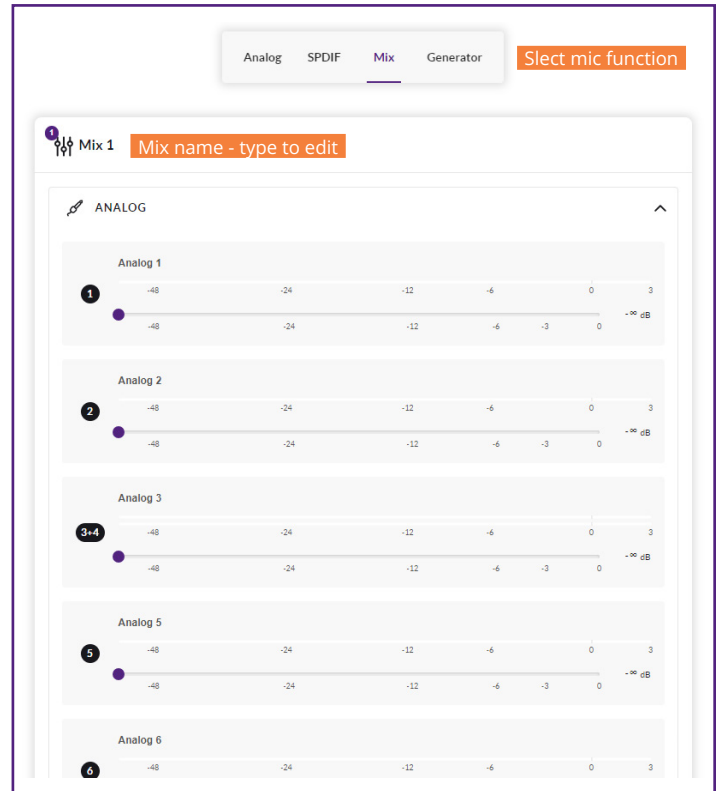

Diagram 6D  
Input Mix display



*Note: The number of individual mixes possible is equal to the number of amplifier analog outputs (two outputs enables two mixes, four outputs enables four mixes, eight outputs enables eight mixes). Note: Mix inputs are muted by default with their level adjustment sliders set to zero. Mix operations take place following high-pass filter, input equalization and mono/stereo selection.*

A pink noise or sine wave audio signal generator, appropriate for audio system testing and set up, can also be enabled, disabled, and adjusted for gain and frequency via the Input Tab. Diagrams 6B, 6C, and 6D illustrate the Input Tab, Input EQ and Input Mix displays respectively.

### 6.3.2 Zone Tab

The Zone Tab enables installation zones to be defined and named, and provides access to further sub-menus. Zones might be bar or restaurant areas for example, or different rooms in a home. For all Zone Tab menus, the installation zone under configuration is selected by highlighting one of the zone identifiers (A to H depending on amplifier output count) at the top of the display. Diagram 6E and 6F illustrate the Zone Tab and Zone Source menu displays.

- The Source menu enables inputs to be assigned to zones and Input Priority or Input Ducking to be configured. The Input Priority function enables an alternative input to replace and mute the input primarily routed to the zone under configuration when the alternative input exceeds a preset level.

# Configuration

The **Input Ducking** function enables an alternative input to replace and attenuate the input primarily routed to the zone under configuration when the alternative input exceeds a preset level.

*Note: Input Priority and Input Ducking parameters can be either set to default values or their Threshold, Attack, Hold and Release values set as required. Input Priority can also be set to ignore the volume level set for the specified zone and take a specific override volume.*

- The Volume menu allows minimum and maximum zone volume limits to be set, and enables external GPIO volume control to be applied to individual zones. The GPIO configuration menu can be found under the Settings Tab, and notes on connecting an external volume control via the GPIO interface can be found in Section 6.5 of this manual.

**Diagram 6E**  
Zone Tab display

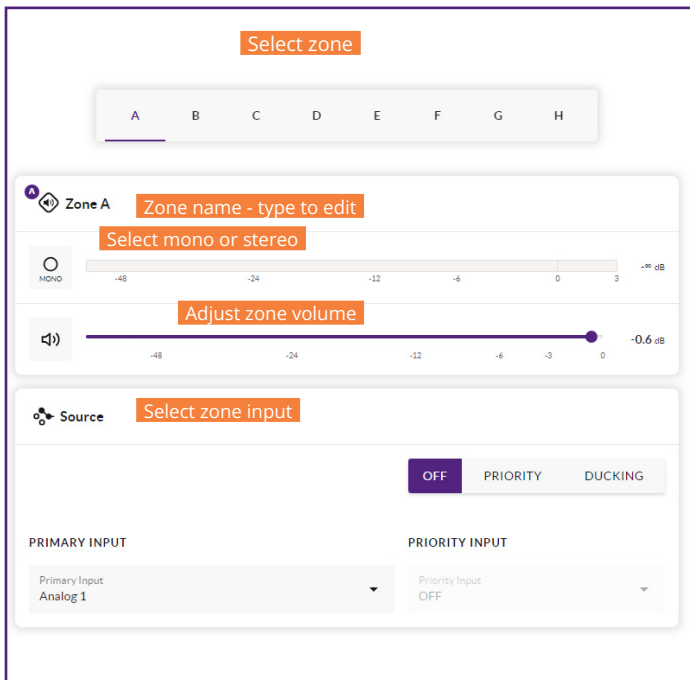

**Diagram 6F**  
Zone Source menu display

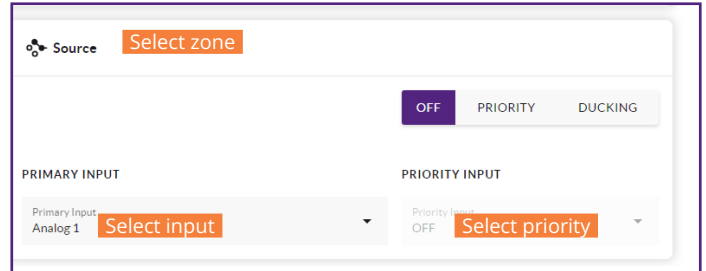

*Note: If an amplifier is controlled via a third-party control system API, volume level limits set via the Input Tab will not apply.*

- The Restrictions menu enables zone inputs or input mixes to be restricted from routing to particular zones.

*Note: Routing restrictions cannot be applied to priority zone inputs.*

*Note: If an amplifier is controlled via a third-party control system API, input routing restrictions set via the Input Tab will not apply.*

- The Compressor option enables default or custom signal compression to be applied to individual zones.

*Note: Compression can be useful to reduce the volume difference between loud and quiet audio material. The lower the compression threshold is set, the more the difference between loud and soft will be reduced. The overall zone volume may need to be increased when compression is used. The default compression parameters are appropriate for most installations.*

# Configuration

## 6.3.3 Output Tab

The Output Tab (Diagram 6G) enables amplifier outputs to be named, linked to zones, and provides access to Delay, Room Equalizer and Speaker Preset menus. Diagram 6H illustrates the Output Tab display.

For all Output Tab menus, the amplifier output under configuration is selected by highlighting one of the output identifiers at the top of the display.

Note: The number of individual outputs available for configuration will depend on the input, zone, and output mode configuration. The diagrams following illustrate a four output amplifier.

- The Routing menu enables zones to be assigned to amplifier outputs.

Note: Routing for zones specified as stereo will automatically offer three output options: left channel, right channel or summed mono. The summed mono signal can potentially be used to drive a mono subwoofer or a 70/100V mono speaker line.

- The Delay menu enables delay to be applied to

Diagram 6G

Output Tab display

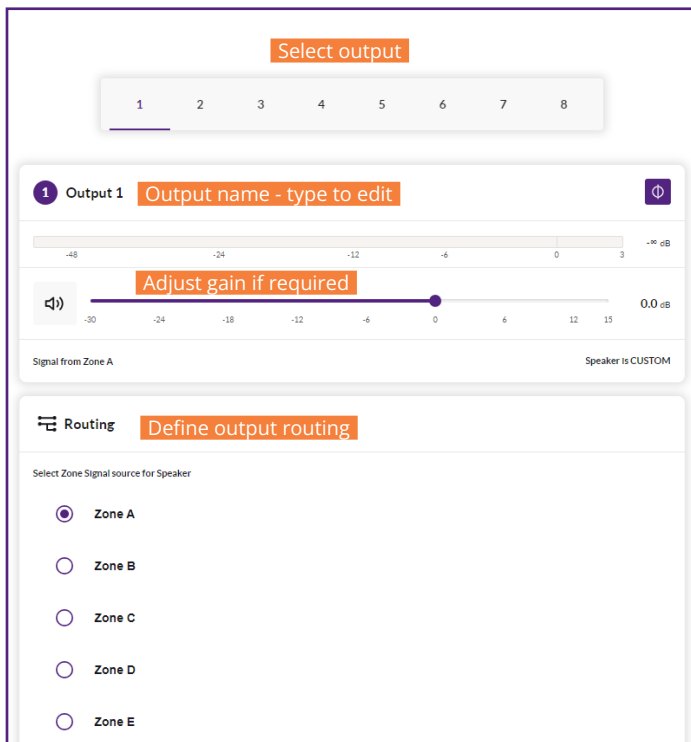

individual amplifier outputs.

- The Equalizer menu enables parametric equalization to be applied to individual amplifier outputs. Equalizer settings configured for one amplifier output can be copied and applied to other outputs.
- The Speaker Preset menu enables a set of speaker parameters to be adjusted, and preset configurations to be created, exported, imported, or cleared.

Speaker Presets can be simply applied to the selected amplifier output or imported, chosen from a library, exported or cleared. The preset configurations can include any or all of the parameters described in Section 6.3.4 and can be locked to prevent inadvertent modification. Diagrams 6I, 6J, and 6K illustrate the application of speaker presets.

Speaker Preset data provided by third parties for use with specific speakers can be imported and applied to amplifier outputs. To import speaker preset parameters follow the steps described below and illustrated in the diagrams.

1. Select either the IMPORT PRESET FROM LIBRARY or SELECT PRESET FROM FILE option from the Speaker Preset menu. If no import option is visible, select CLEAR to delete any existing speaker preset data.

Diagram 6H  
Speaker Preset Parameters

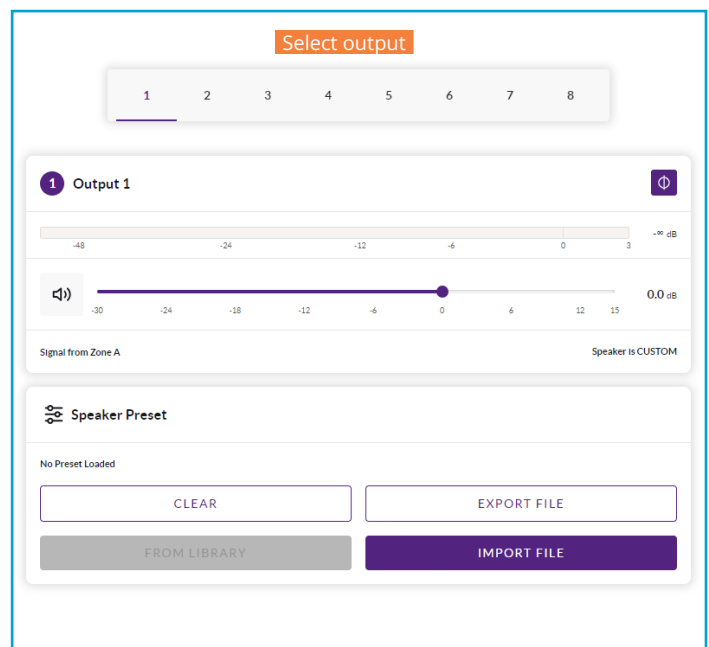

# Configuration

**Diagram 6I**  
Speaker Preset import file selection

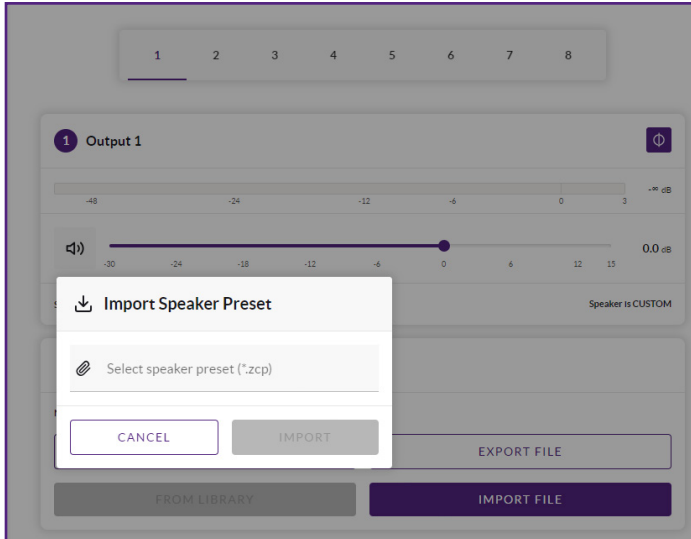

Note: The *SELECT PRESET FROM LIBRARY* option will be unavailable if no speaker preset libraries have been created. Speaker preset library creation and management is described in Section 6.3.5.

2. Select the appropriate '.zcp' format speaker preset data file to import from either a Library or a computer folder. The preset data will be applied to the selected amplifier output as soon as the file import is complete.
3. If the Speaker Preset data requires modification it can be customized by selecting the CUSTOMIZE PRESET option.

**Diagram 6J**  
Speaker Preset applied

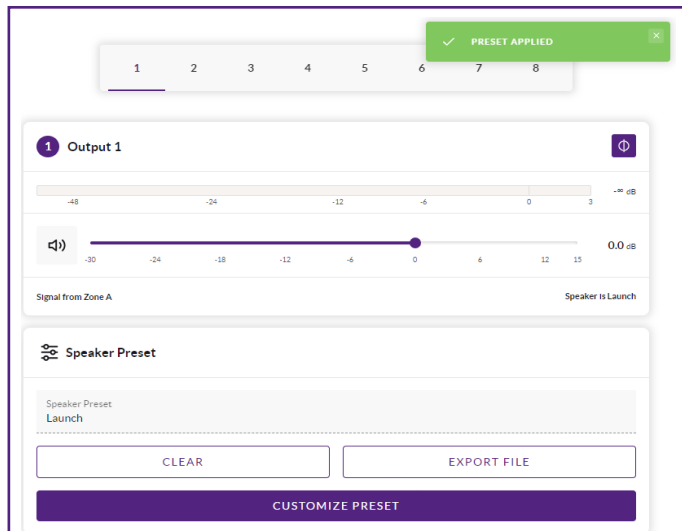

**Diagram 6K**  
Speaker Preset parameter adjustment

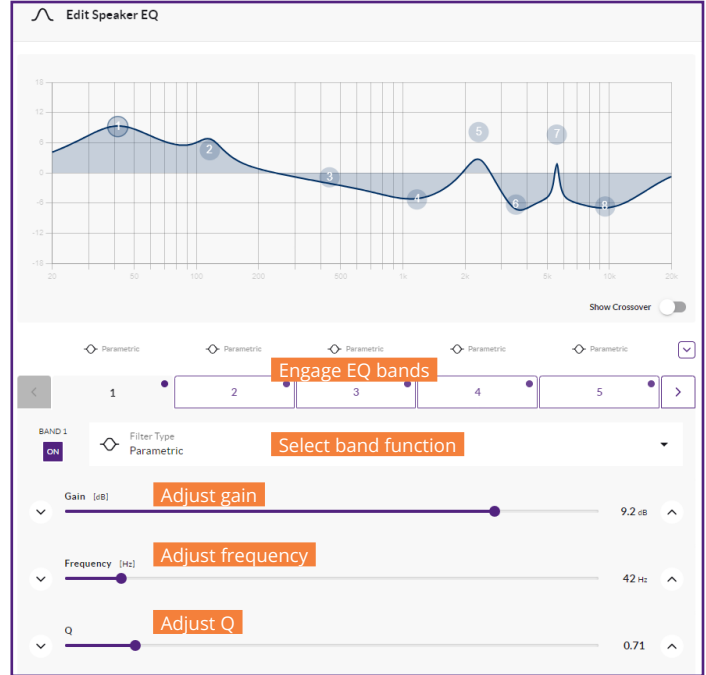

Note: If an imported Speaker Preset data file includes locked parameters, they will be unavailable for modification.

### 6.3.4 Speaker Preset Menu Parameters

- The **Crossover & Gain** preset menu enables high or low-pass crossover filters and gain adjustment to be applied to individual amplifier outputs.
- The **Speaker EQ** preset menu enables parametric equalization to be applied to individual amplifier outputs.
- The **FIR** preset menu enables FIR (Finite Impulse Response) based equalization filter coefficients generated by external speaker measurement software to be imported and applied to individual amplifier outputs. The FIR filter has 512 taps at 48kHz.

Note: FIR coefficient files in either .csv or .txt format can be imported.

# Configuration

- The **Driver Alignment** preset menu enables delay to be applied to individual amplifier outputs.
- The **Polarity** preset menu enables the polarity of individual amplifier outputs to be reversed.
- The **Limiter** preset menu enables signal limiting to be engaged or bypassed on individual amplifier outputs. Clip limiting, Peak limiting and RMS limiting can be individually or collectively engaged. The Clip limiting function offers Fast and Normal response time options. The Peak limiting function can be set to either Automatic or Manual parameter values. The RMS Limiter has default parameter values that can be adjusted but has no automatic option.

*Note: In automatic mode, the peak limiter parameters adjust automatically in response to Crossover & Gain high-pass filter settings.*

- The **Output Mode** preset menu enables individual amplifier outputs to be switched off or configured for Lo-Z or Hi-Z modes. In Hi-Z modes, a high-pass filter can also be configured and applied to the output. The number of outputs available will depend on the amplifier model, input setup and zone setup. For example, a two output amplifier will have two outputs available if Lo-Z mode is selected but only one output available if Hi-Z mode is selected.

*Note: Use of a high-pass filter with Hi-Z mode loudspeakers is useful to avoid the possibility of distortion caused by low frequency line transformer saturation. Begin with the default filter setting of 70Hz. If low frequency distortion is still audible, increase the frequency setting one step at a time until the distortion is no longer audible.*

### 6.3.5 Settings Tab

The Settings Tab enables miscellaneous amplifier settings to be configured and installation data to be recorded. The Settings Tab provides access to further sub-menus. Diagram 6L illustrates the **Settings** Tab.

- The **System Information** menu provides text fields for the recording of installation data. The **Device** menu records amplifier specific information such as the model number and firmware version. A firmware update routine and identifier button can also be found under the Device menu.
- The **Device** menu records amplifier specific information such as the model number and firmware version. A firmware update routine and identifier button can also be found under the Device menu.

**Diagram 6L**  
Settings Tab menu

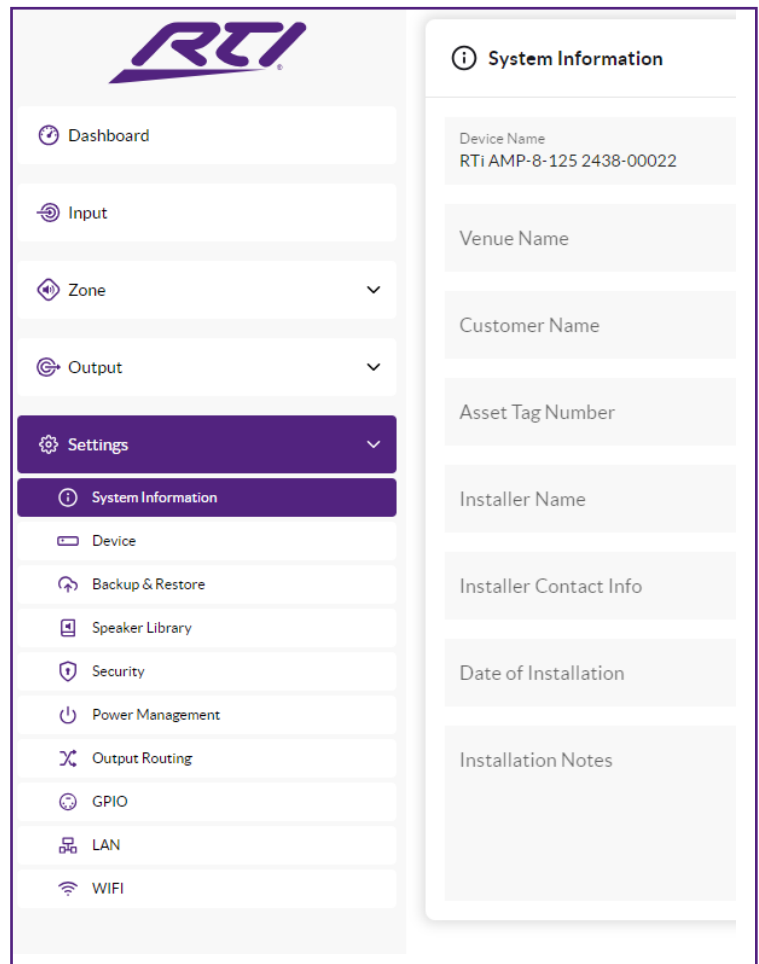



# Configuration

- The **Backup & Restore** menu enables amplifier configuration data to be downloaded to an external archive, and enables previously saved configuration files to be uploaded and adopted by the currently connected amplifier.
- The **Speaker Library** menu enables management of speaker preset libraries. Existing libraries of speaker preset files (.zcl) can be created or imported, and existing libraries edited or fully deleted. Diagram 6M illustrates the creation and management of speaker preset libraries.
- The **Security** menu enables a password to be set in order to protect against unauthorised access to the amplifier Control Web App. Password protection is particularly important when an amplifier is connected to a wired network as the a WiFi password is no longer required to gain access to Control Web App.

*Note: It is recommended that a Control Web App password is different from that required to gain access to the amplifier via WiFi.*

- The **Power Management** menu enables various automatic switch-on options to be engaged. The Power Management menu also offers timed Standby and Mute functions.

*Note: In Eco mode the network is switched off during standby.*

- The **Output Routing** menu enables specified inputs or zones to be routed to the amplifier S/PDIF outputs. The output level can also be adjusted.

Any zone or input can be routed to either digital output, including inputs not actively assigned to a zone. Primary or priority input status is immaterial. The specified input is always routed to the specified output to be available for use by downstream devices.

*Note: When a zone is selected for the digital S/PDIF output - the output signal is variable.*

*Note: The digital output function is especially useful when amplifiers are to be daisy chained and a specific input; a central paging mic, for example, is required to be routed to multiple amplifiers.*

- The **GPIO** menu enables configuration of the multi-purpose GPIO interface pins. A description of the individual settings is detailed in AMP-4-125 and AMP-8-125 Control.
- The **LAN** menu enables configuration and reset of the wired network options and parameters.

**Diagram 6M**  
Speaker Library Creation and Management

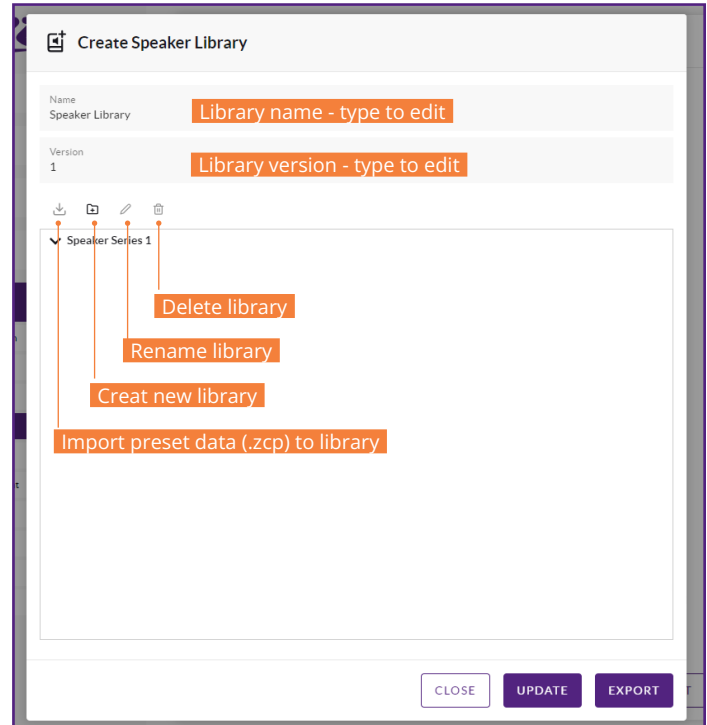

- The **WiFi** menu enables configuration and reset of the wireless network options and parameters.

## 6.4 Setup and Signal Routing

Thanks to their network based configuration features, the AMP-4-125 and AMP-8-125 amplifiers offer considerable versatility in terms of sources, signal routing, installation zones and output modes. Inputs can be freely assigned to installation zones, and those zones assigned freely to the available amplifier outputs in either Lo-Z or Hi-Z modes.

This versatility enables, for example, one amplifier simultaneously to drive both Lo-Z and Hi-Z speakers, or for different inputs to be routed to different output zones.

The following paragraphs describe and illustrate the recommended procedure for configuring input, zone and output routing. A general signal flow schematic is also illustrated in Diagram 6N.

# Configuration

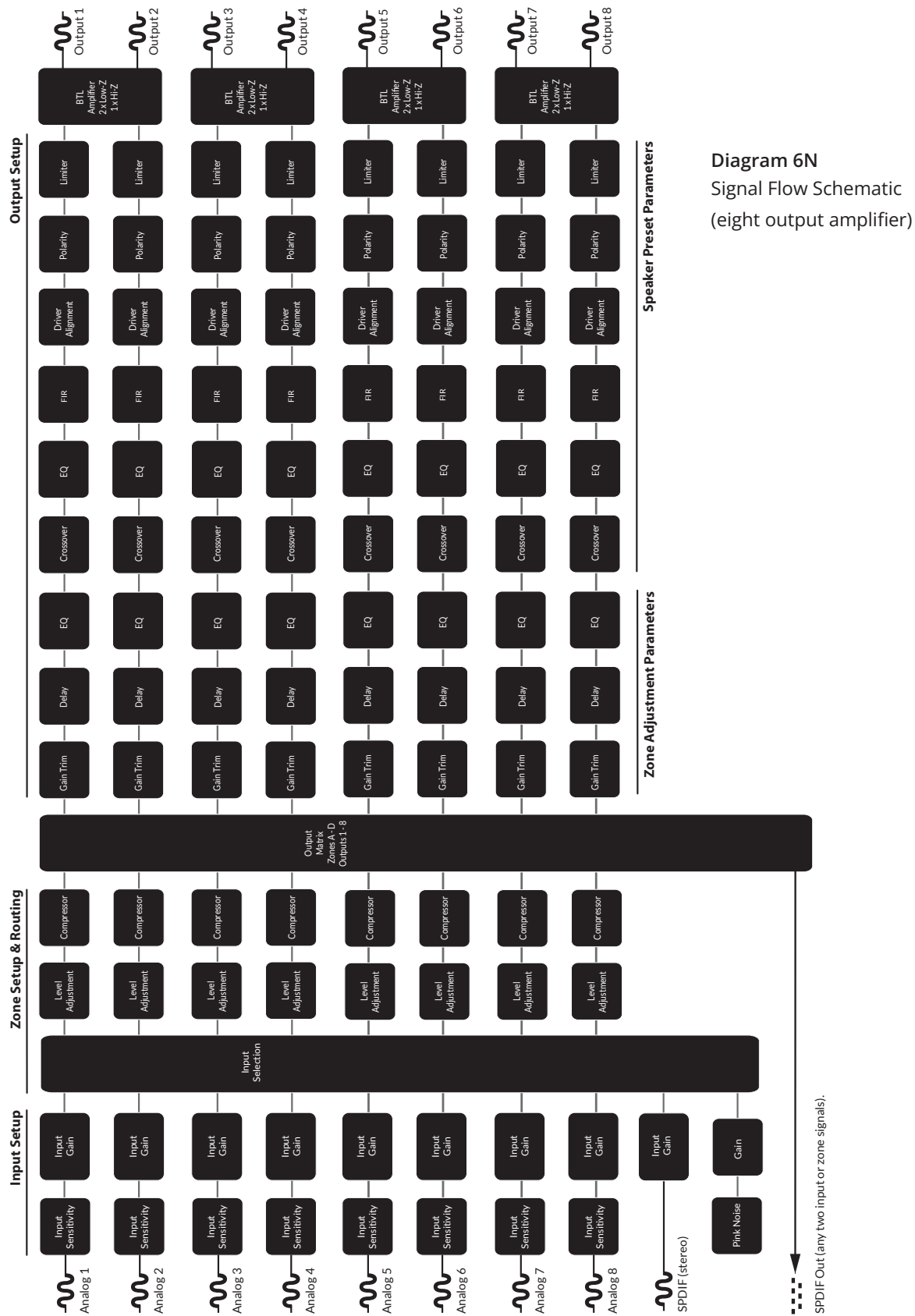

Diagram 6N  
Signal Flow Schematic  
(eight output amplifier)

# Configuration

## 6.4.1 Input Setup

Open the configuration Dashboard and select the Input Tab. The Input Tab is shown in Diagram 6B.

- To edit default input names simply select and type in the Input Name field.
- Define a mono or stereo input by selecting the appropriate option. Defining a stereo input will reduce the total number of discrete inputs available.
- Select an input sensitivity option from the drop-down menu: +14dB, +4dB, -10dB and 'microphone' options are available. Generally, the +14dB or +4dB options are appropriate for 'professional audio' source hardware with balanced outputs, while the -10dB option is more appropriate for 'consumer audio' source hardware with unbalanced outputs. The 'microphone' option provides the significantly greater sensitivity required for microphones.

*Note: Only dynamic microphones are suitable for connection. Phantom power for condenser microphones is not provided.*

- If necessary, adjust the input gain using the slider or up/down icons. Gain adjustment is intended to be used for fine output level adjustment following initial use. If necessary, adjust the input EQ using the 5 band equalizer.

## 6.4.2 Zone Setup & Routing

Open the configuration Dashboard and select the Zone Tab. The Zone Tab is shown in Diagram 6E.

- Select the zone to be configured. The number of zones available and their channel format (stereo or mono) will depend on the amplifier model, input setup and output mode (Lo-Z or Hi-Z).
- The AMP-4-125 can have the following zones configured:
  - 2 x stereo Lo-Z zones
  - 4 x mono Lo-Z zones
  - 2 x mono Hi-Z
  - 1 x mono Hi-Z + 1 x stereo Lo-Z zone
  - 1 x mono Hi-Z + 2 x mono Lo-Z zones
- The AMP-8-125 can have the following zones

configured:

- 4 x stereo Lo-Z zones
- 8 x mono Lo-Z zones
- 4 x mono Hi-Z or zones
- 2 x mono Hi-Z or + 2 x stereo Lo-Z zone
- 2 x mono Hi-Z or + 4 x mono Lo-Z zones

Note: When configured in Hi-Z mode the AMP-4-125 and AMP-8-125 amplifiers operate in 'bridged' format where the output of two channels is combined. This means that the number of output channels available in Hi-Z mode is half that available in Lo-Z mode .

*Note: Mono signals might be mono at source, created though combining the left and right channels of a stereo signal (summed mono) or treating the left and right channels of a stereo signal independently (split mono).*

- Name zones by typing in the Zone Name field.
- Adjust the zone volume if required by using the slider.
- Define a mono or stereo zone by selecting the appropriate option. Defining a stereo zone will reduce the total number of further zones available.
- Specify an input for the zone by selecting from the drop-down menu. Selecting a stereo input for a mono zone will automatically sum the stereo channels to mono.

## 6.5 GPIO Setup and Connection

The AMP-4-1256 and AMP-8-125 provide a GPIO socket that enables remote control of volume, standby, mute and trigger functions. The GPIO connector pin functions are described in the GPIO Settings menu illustrated in Diagram 6Q. The connection of GPIO based remote volume control and standby/mute are illustrated in Diagram 6P and Diagram 6Q respectively.

# Configuration

Diagram 6O

GPIO Settings Menu

## 6.5 GPIO Setup and Connection

The AMP-4-125 and AMP-8-125 amplifiers provide a GPIO socket that enables remote control of volume, standby, mute and trigger functions. The GPIO connector pin functions are described in the GPIO Settings menu illustrated in Diagram 6O. The connection of GPIO based remote volume control and standby/mute are illustrated in Diagram 6P and Diagram 6Q respectively.



Note: The GPIO connector must not be used for any unintended purpose. Amplifier damage may result from incorrect use of GPIO.



Note: Shielded cable must be used when connecting standby switches and potentiometers via GPIO.



Note: GPIO Pin 8 has a low output impedance and is able to supply a maximum current of 10mA.



Note: GPIO Pin 1 and Pin 3 both offer ground connections: Pin 1 is connected directly to the amplifier chassis. Pin 3 is connected to the chassis via a 220 Ohm resistor. The 'soft ground' connection of Pin 3 is potentially useful for managing ground loops that may cause audible hum.

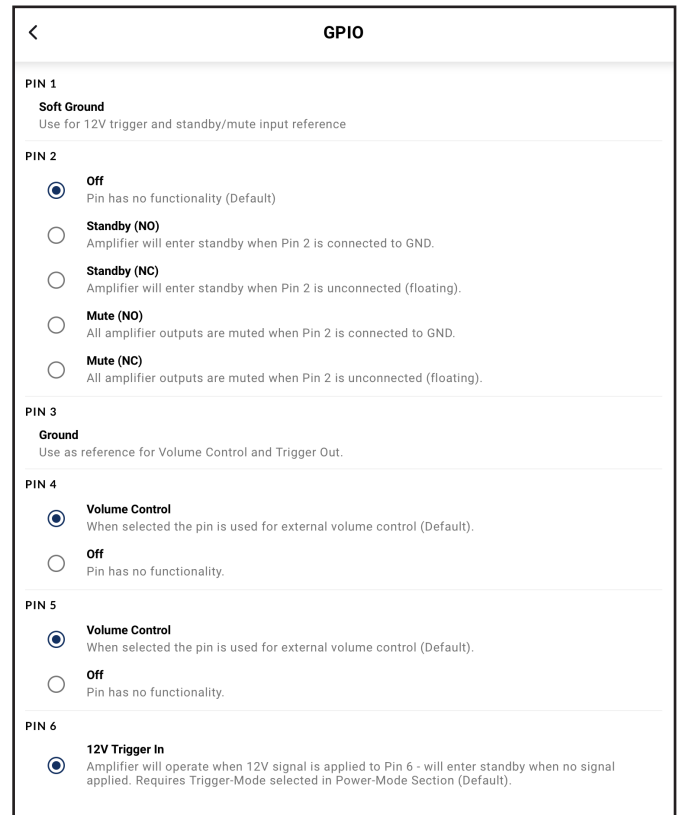

Diagram 6P

Potentiometer connections for remote volume control via GPIO.

Note: Diagram 7E illustrates use of the GPIO connector.

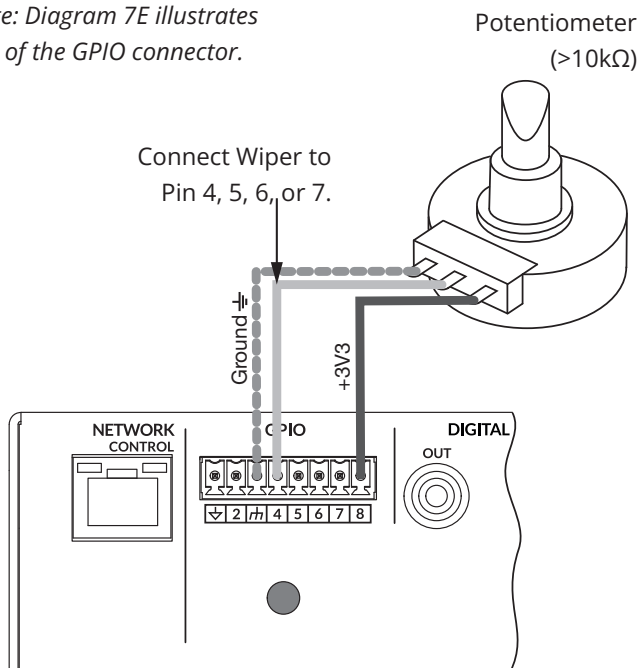
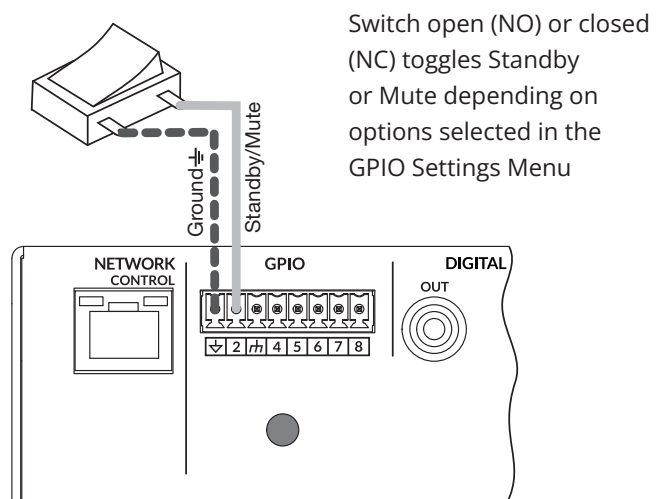

Diagram 6Q

Connections for remote standby/mute switch via GPIO.

Note: Diagram 7E illustrates use of the GPIO connector.



# Connections

## 7. Connections

AMP-4-125 and AMP-8-125 rear panel connections are illustrated in Diagrams 7A and 7B.

### 7.1 Mains Power Connection

These amplifiers incorporate a power factor corrected universal power supply and can be used with mains input voltage from 100V AC to 240V AC, 50/60Hz. Use the mains cable supplied with the amplifier.

The amplifiers have no mains power switch and are operational as soon as mains power is connected. Ensure that all signal, GPIO and output connections are made before connecting the amplifier to mains power.

### 7.2 Input Connection

Both amplifier models provide four balanced or unbalanced analog audio inputs and a stereo S/PDIF digital audio input. Any input channel can be routed to any output channel. Input routing options can be configured via the amplifier network interface. See Section 6 of this manual.

#### Analog Inputs

Analog inputs are of line level format with a default input sensitivity of +4dBu (full output voltage swing/sensitivity) in all output modes. Input signal levels up to +24dBu can be handled without input clipping. Input sensitivity options can be set via the amplifier network interface. See Section 6 of this manual.

Balanced input connections to the amplifiers are made via male 'Euro Block' connectors. Connecting cables to the supplied female input connectors is illustrated in Diagram 7C.

Unbalanced input connections to the amplifiers are made via RCA phono sockets connected in parallel with the balanced inputs.

#### Digital Outputs

For both amplifiers, S/PDIF stereo digital audio output connections are made via a single RCA Phono socket. The S/PDIF output signal can be routed from any input or zone and is intended to be used for daisy-chaining multiple amplifiers.

*Note: See the Output Routing paragraphs of Section 6.3.3 for more information on Digital Output configuration.*

*Note: 75Ω RCA Phono cables specifically intended for digital audio should always be used for S/PDIF connections. Standard Phono cables can be used but may not result in optimal performance.*

*Note: The S/PDIF output level is by default set at -10dB to reduce the possibility of downstream input clipping.*

Diagram 7A

AMP-4-125 rear panel connections.

*Note: Two output amplifier model connection sockets differ only in the deletion of channel 3 and channel 4 output.*

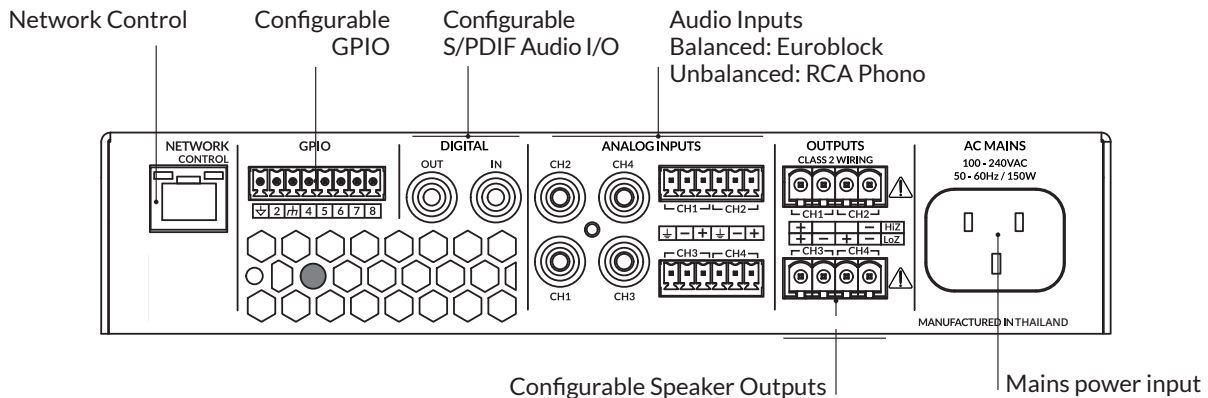

# Connections

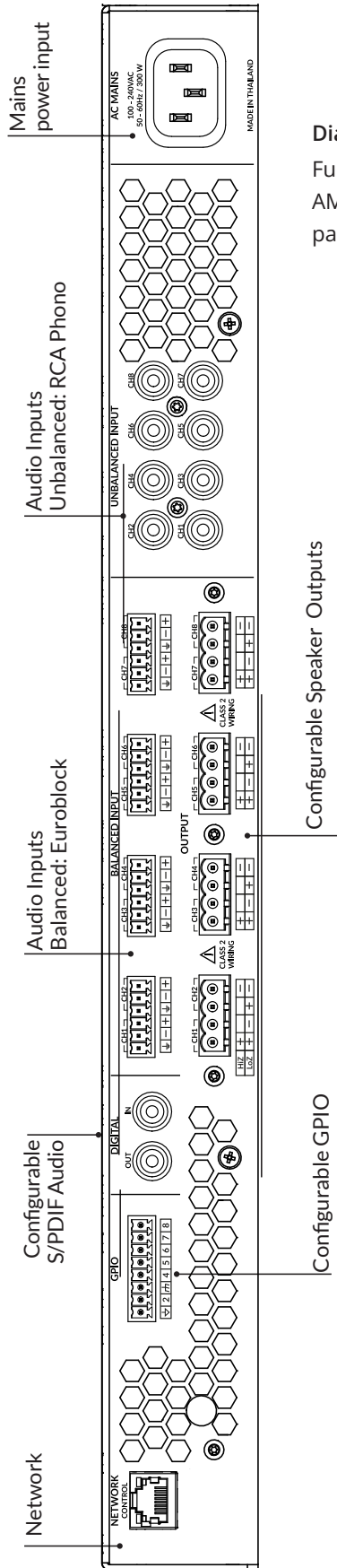

**Diagram 7B**  
Full rack width  
AMP-8-125 rear  
panel connections.

## 7.3 Output Connections

Output connections from the amplifiers are achieved via male 'Euro Block' connectors. Ensure that speaker connection polarity is correct throughout the installation:

In the case of Lo-Z speaker connections, positive (+) amplifier terminals should always be connected to positive speaker terminals and negative (-) amplifier terminals always connected to negative speaker terminals.

In the case of Hi-Z speaker connections, the two speaker cable conductors should be connected between the positive (+) terminal of Output 1 and the negative terminal (-) of Output 2, and likewise for any additional Hi-Z outputs.

Output mode options (Lo-Z or Hi-Z) can be configured via the amplifier network interface. See Section 6 of this manual.

Connecting cables to the supplied female output connector is illustrated in Diagram 7D.

# Connections

## 7.5 Speaker Cable Gauge

The speaker connection cable gauge should be chosen appropriately to reflect the type of installation. The adjacent tables specify the appropriate cable gauge for less than 0.5dB cable loss with different installation types and cable lengths.

## 7.5 GPIO Connections

If any GPIO functionality is required, cables will need to be connected to the supplied GPIO connector. Connecting cables to the GPIO connector is illustrated in Diagrams 7E.

## 7.6 Network Connections

These amplifiers are TCP/IP network connected devices that are configured via a web page based interface. Wired (Ethernet) and wireless (WiFi) connection options are available. Connecting these amplifiers to a TCP/IP network is described in Section 6 of this manual. If a wired connection is used, connect an Ethernet cable to the amplifier rear panel Network Control socket.

**Cable Gauge Table**

Lo-Z installations, 0.5dB attenuation. 4 Ω & 8 Ω loads

Cable Cross Section (mm <sup>2</sup> )	Cable Gauge (AWG)	Max Cable Length (Metres, 4 Ω load)	Max Cable Length (Metres, 8 Ω load)
0.75	≈18	5	10
1.5	≈16	10	20
2.5	≈14	17	35

**Cable Gauge Table**

70V Hi-Z installations, 1.0dB attenuation  
20 speakers evenly distributed

Cable Cross Section (mm <sup>2</sup> )	Cable Gauge (AWG)	Max Cable Length (Metres), (125 W/channel)	Max Cable Length (Metres), (250 W/channel)
0.75	≈18	90	45
1.5	≈16	180	90
2.0	≈14	<250	150

*Note: Cable lengths should not exceed 250m.*

**Cable Gauge Table**

100V Hi-Z installations, 1.0dB attenuation  
20 speakers evenly distributed

Cable Cross Section (mm <sup>2</sup> )	Cable Gauge (AWG)	Max Cable Length (Metres), (125 W/channel)	Max Cable Length (Metres), (250 W/channel)
0.75	≈18	190	90
1.5	≈16	<250	180
2.0	≈14	<250	<250

*Note: Cable lengths should not exceed 250m.*

# Connections

**Diagram 7C**  
Balanced analog input cable connections.

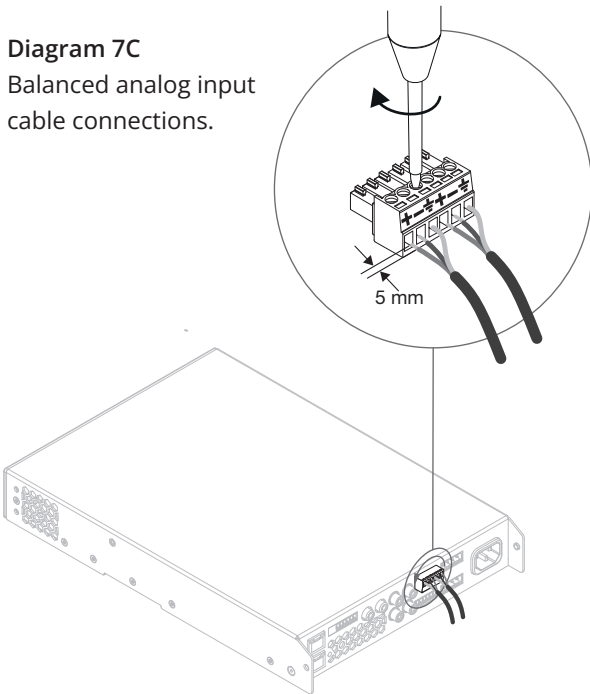

**Diagram 7E**  
GPIO cable connections.

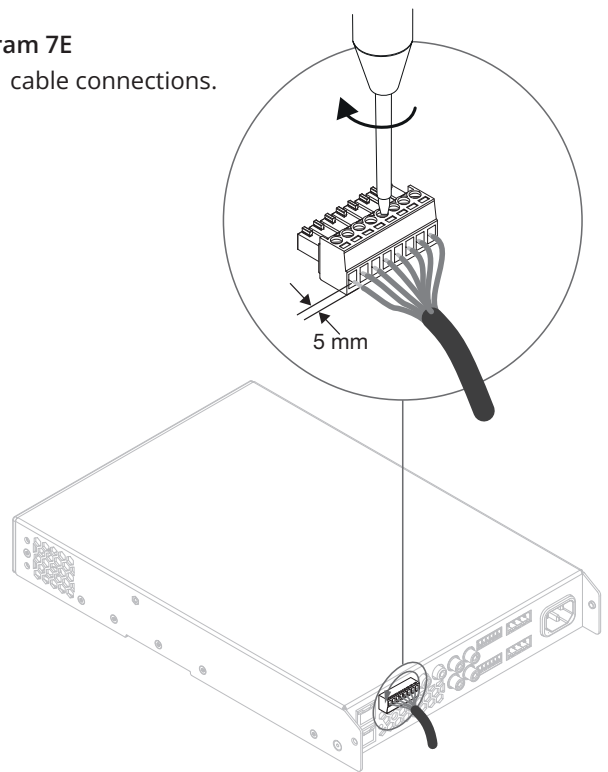

**Diagram 7D**  
Output cable connections.

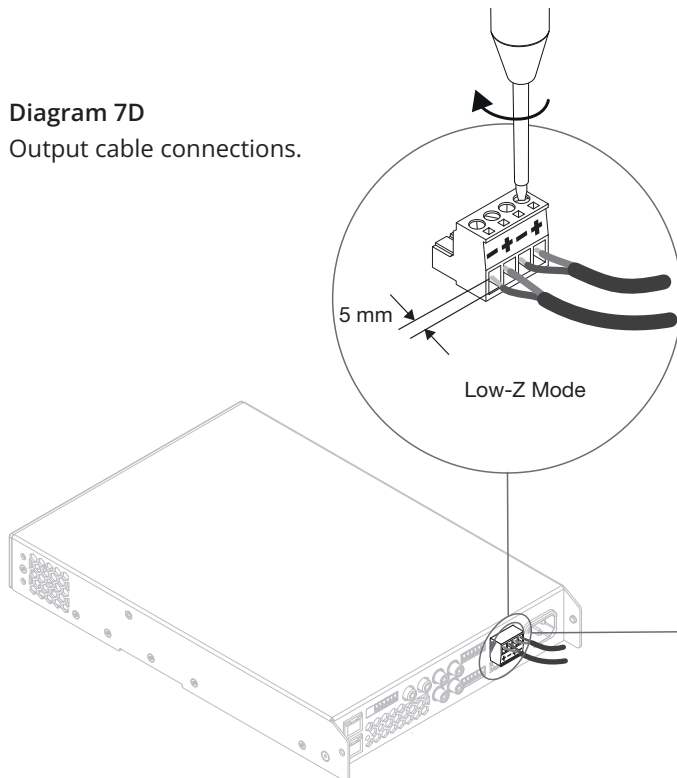

Note: Input, output and GPIO connection socket use is the same for four and eight channel output amplifiers.



The exclamation point printed next to the output terminals of the amplifiers is, in addition to the CLASS 2 WIRING text, intended to alert users to the risk of hazardous voltages. Output connectors that could pose a risk are marked with the exclamation point. Do not touch the output terminals while the amplifier is switched on. Make all connections with the amplifier switched off.



# Operation

## 8. Operation

Once all connections have been made and configuration options selected, the AMP-4-125 or AMP-8-125 is ready for use. If an input signal above -60dB is present on any input, the front panel Input and Standby indicators will illuminate green to indicate normal amplifier operation. Audio will be heard from any connected speakers.

*Note: The amplifiers will not switch on from Standby Mode unless an input signal is present, a network 'ON' command is received, or an external standby switch (or 12V trigger) is operated. Standby behaviour can be configured via the Power Management menu of the Settings Tab.*

Amplifier outputs will mute if no input signal is present for 5 minutes, and the amplifier will switch automatically to Standby Mode if no signal is present on any input for more than 15 minutes. Alternative standby and mute delay times can be selected via the Settings Tab. Amplifier cooling fan speed is temperature controlled. The fan will switch off when the amplifier enters standby mode.

### 8.1 Front Panel Indicators

AMP-4-125 and AMP-8-125 amplifier front panel indicators illuminate to indicate the following operational states:

- Status:** Off – Mains power disconnected.  
Green – Amplifier operational.  
Pulse Green – Standby Mode.  
Amber – GPIO triggered Standby Mode
- Input:** Off – No input signal present.  
Green – Signal present on one or more inputs.  
Amber – Signal limiting/clipping on one or more inputs.
- Output:** Off – No output signal present.  
Green – Signal present on one or more outputs.  
Amber – Signal limiting/clipping on one or more outputs.  
Red – One or more channel pair is in overload/protection mode.

- Network:** Off – No Ethernet network detected.  
Green – Ethernet network detected.

- WiFi:** Off – WiFi disabled.  
Green – WiFi enabled.

### 8.2 Automatic Power Sharing

The AMP-4-125 and AMP-8-125 amplifiers incorporate a power sharing feature that automatically shares the total power available from the amplifier's internal power supply across each pair of output channels. If one channel temporarily demands more than the amplifier's continuous power rating while other channel is demanding less, the excess power available from the internal power supply is automatically made available to the over-power channel. Power sharing optimises the amplifier's ability to deliver maximum power into dynamic loudspeaker loads when playing music programme material.

### 8.3 Default Reset

Both amplifiers can be returned to their default settings via either the Control Web App Settings Tab or the hardware reset pinhole button. The reset pinhole button is located on the underside panel of the amplifier.

To reset the amplifier using the pinhole button, follow the steps below:

- Disconnect the amplifier from mains power.
- Use an appropriate tool to press and hold the reset pinhole button while simultaneously reconnecting mains power.
- Continue to hold the reset pinhole button for 3 seconds as the amplifier restarts.

The amplifier will restart with all settings at their default state. Any previously configured settings will be deleted.

# Specifications

Model	AMP-4-125	AMP-8-125
Total System Power	500 W	1000 W
Output Power @ 4/8Ω	4 x 125 W	8 x 125 W
Output Power @ 70/100V*	2 x 250 W	4 x 250 W
Powershare (up to) Across all channels**	2 x 250 W	4 x 250 W
Power Consumption	150W	300 W
Dimensions	44 x 220 x 319mm (1.7 x 8.7 x 12.6 in)	44 x 220 x 319mm (1.7 x 17.3 x 12.6 in)
Weight	2.8kg (6.2 lbs)	3.8 kg (8.4 lbs)
Power Ratings	1% THD @ 120Vac and 230Vac	
Output Circuitry	UMAC™ Class D - full bandwidth PWM modulator with ultra-low distortion	
Output Voltage	70Vp / 140Vpp (unloaded) // Bridged 140Vp / 280 Vpp (unloaded)	
Signal To Noise-Ratio	>106dB (A-weighted, 20Hz-20kHz, 8Ω load)	
THD+N (typical)	< 0.05% (20Hz-20kHz, 8Ω load, 3dB below rated power)	
Frequency Response	20Hz-20kHz (+0/-0.8dB (8Ω load, 3dB below rated power)	
Protection Circuits	Short circuit, DC, Undervoltage, Temperature, and Overload protection	
Power Supply	UREC™ universal mains switch mode power supply with Power Factor Correction (PFC) and standby converter	
Operating temperature	0-40°C	
Operating Voltage/Frequency	Universal Mains, 100V-240V, 50Hz-60Hz	
Standby Consumption	< 0.6W	
Accessories	2x Rack ears 1x ½ rack plate extension 2x ½ rack mounting plates 2x Rear supports	2x Rack ears (fitted) 2x Rear supports

\* 100V line mode is @ -1dB (≈ 90 V)

\*\* AMP-4-125 may only Powershare across Ch1-2 and Ch3-4

AMP-8-125 may only Powershare across Ch 1-2, Ch 3-4, Ch 5-6 and Ch 7-8

## Specifications

### Power Efficiency Data

The following table describes the efficiency and power performance of the AMP-4-125 and AMP-8-125 amplifiers. The table also includes the derived thermal losses.

1/8th Full Power						
Model	Load (Ohms)	Power In (W)	Power Out (W)	Efficiency (%)	Thermal Loss (W)	Thermal Loss (BTU)
AMP-4-125	4	107	62.5	58.6	44.5	152
AMP-8-125	4	200	125	62.5	75	256

Standby and Idle					
Model	Standby (mW)	Idle @ 120V (W)	Idle @ 120V (BTU)	Idle @ 230V (W)	Idle @ 230V (BTU)
AMP-4-125	<500*	14.5	49	15.9	54
AMP-8-125	<500*	27.7	94	30.2	103

\*As per compliance to ErP

### Propagation Delay Data

The following tables describes the input/output latency performance of AMP-4-125 and AMP-8-125 amplifiers.

AMP-4-125			
		OUT	
		Analog	S/PDIF
IN	Analog	1177 $\mu$ S	458 $\mu$ S
	S/PDIF	1833 $\mu$ S	1104 $\mu$ S

AMP-8-125			
		OUT	
		Analog	S/PDIF
IN	Analog	1307 $\mu$ S	600 $\mu$ S
	S/PDIF	1955 $\mu$ S	1250 $\mu$ S